

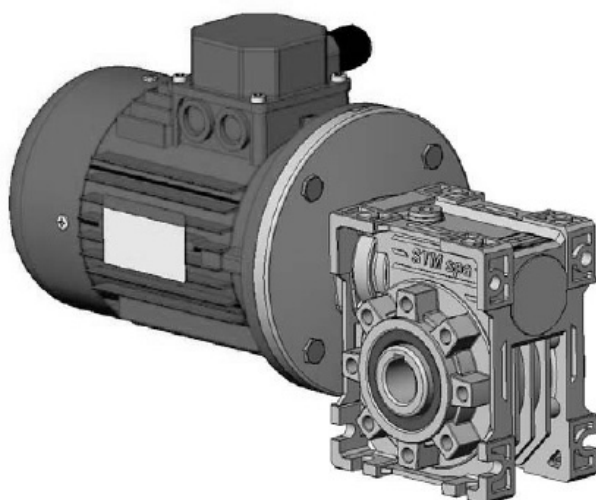

3 УНИВЕРСАЛЬНЫЕ РЕДУКТОРЫ И МОТОР-РЕДУКТОРЫ С ЧЕРВЯЧНОЙ ПЕРЕДАЧЕЙ U-UI-UMI

		Стр.
3.1	Технические характеристики	76
3.2	Обозначения	77
3.3	Исполнения	78
3.4	Смазка	79
3.5	Осевые и радиальные нагрузки	81
3.6	Эксплуатационные показатели редукторов	83
3.7	Эксплуатационные показатели мотор - редукторов	86
3.8	Размеры	91
3.9	Аксессуары: Реактивный кронштейн	93
3.10	Аксессуары: Выходные валы	93
3.11	Шпонки	94

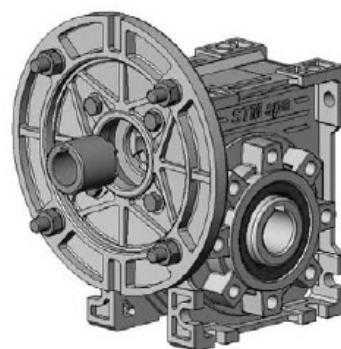



3.1 Технические характеристики

Редукторы производства нашей фирмы изготовлены из высококачественных материалов и имеют современную конструкцию, что гарантирует максимальную надежность и долговечность в работе.

Корпуса, фланцы и лапы изготовлены из алюминия SG-AISi UNI 1706.

Червячные валы изготовлены из стали и подвергнуты цементации, закалке и шлифовке.

Шлифовка зубчатых передач осуществляется с помощью ZI-профиля. Это улучшает контакт между поверхностями зацепления и, следовательно, повышает производительность и снижает уровень шума при работе.

На червячном колесе имеется ступица из чугуна G20, на которую наплавляется бронза GcuSn12 UNI 7013.

Материал соединительной муфты: Латунь OT58 UNI 5705/65

В целях обеспечения долгого срока службы устанавливаются конические роликовые подшипники и радиальные шариковые подшипники.

Особые характеристики:

- Небольшие размеры
- Упрощенные соединения
- Отсутствует фреттинг - коррозия
- Отсутствует вибрация
- Конструкция, гарантирующая эффективность и надежность при тяжелых режимах работы, в случае ударных нагрузок и частых включений.

Материал:

Латунь OT58 UNI 5705/65

Надежность

Выбор такого материала для использования, как латунь, обеспечивает высокий уровень надежности как отдельно взятой детали, так и собранной продукции.

- Отсутствует фреттинг-коррозия;
- Не изнашивается шпонка.

Техническое обслуживание:

- Легкая сборка с двигателем;
- Легкая разборка.

Модульность:

Возможность соединения, особенно используя серии "U", "RMI ... G", - "CRMI ... G" – "S".

Сроки поставки

- Высокая модульность продукции
- Готовые изделия хранятся на складе

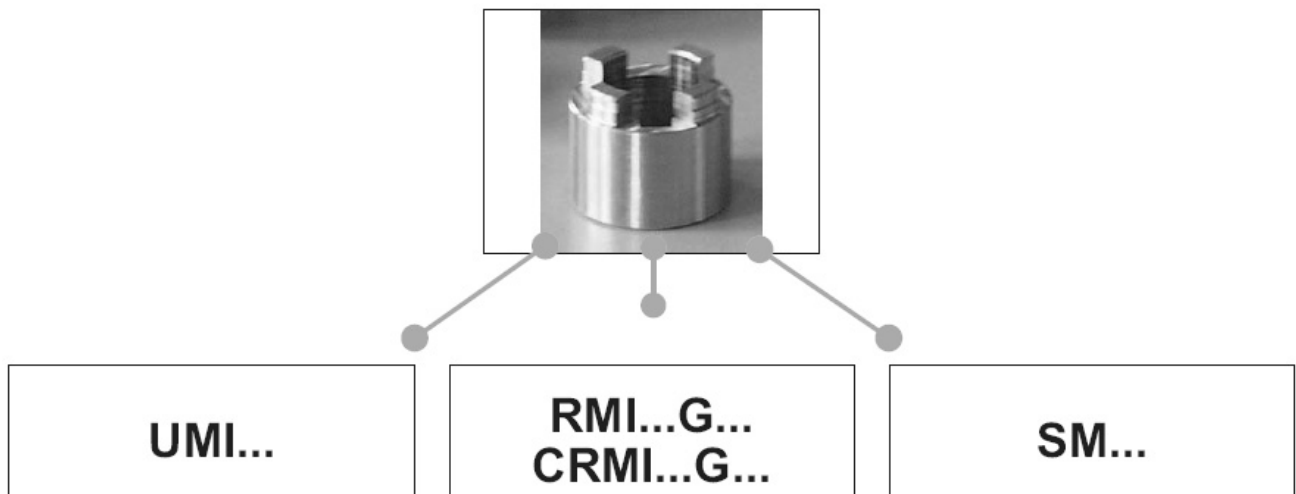



3.2 Обозначения

	Размер	Модель	ir	* IEC	кВт	Кол-во полюсов	Фланец	Пример
UMI	40			63 (B5)				UMI 40 1:20 PAM 63 (B5)
				63 (B14)				
	50	-	См. таблицы	0.13	2	63 (B5)	(стандартный)	UMI 40 1:20 kW 0.18 4 63 (B5)
63	FA	0.18		4	63 (B14)			
UI	75	FB		SX	UI 40 1:20
U	90						↑ только для FA, FB	U 40 1:20

* В случае несоответствия техническим требованиям IEC, укажите диаметр отверстия червячного вала и фланца (т.е.: 14/200).

Другие характеристики, которые должны быть указаны:

- Положение клеммной коробки, если отличается от стандартного (1)
- Левозаходный червяк (специальная модель)
- Конические роликовые подшипники
- Выходные валы

3.3 Модели

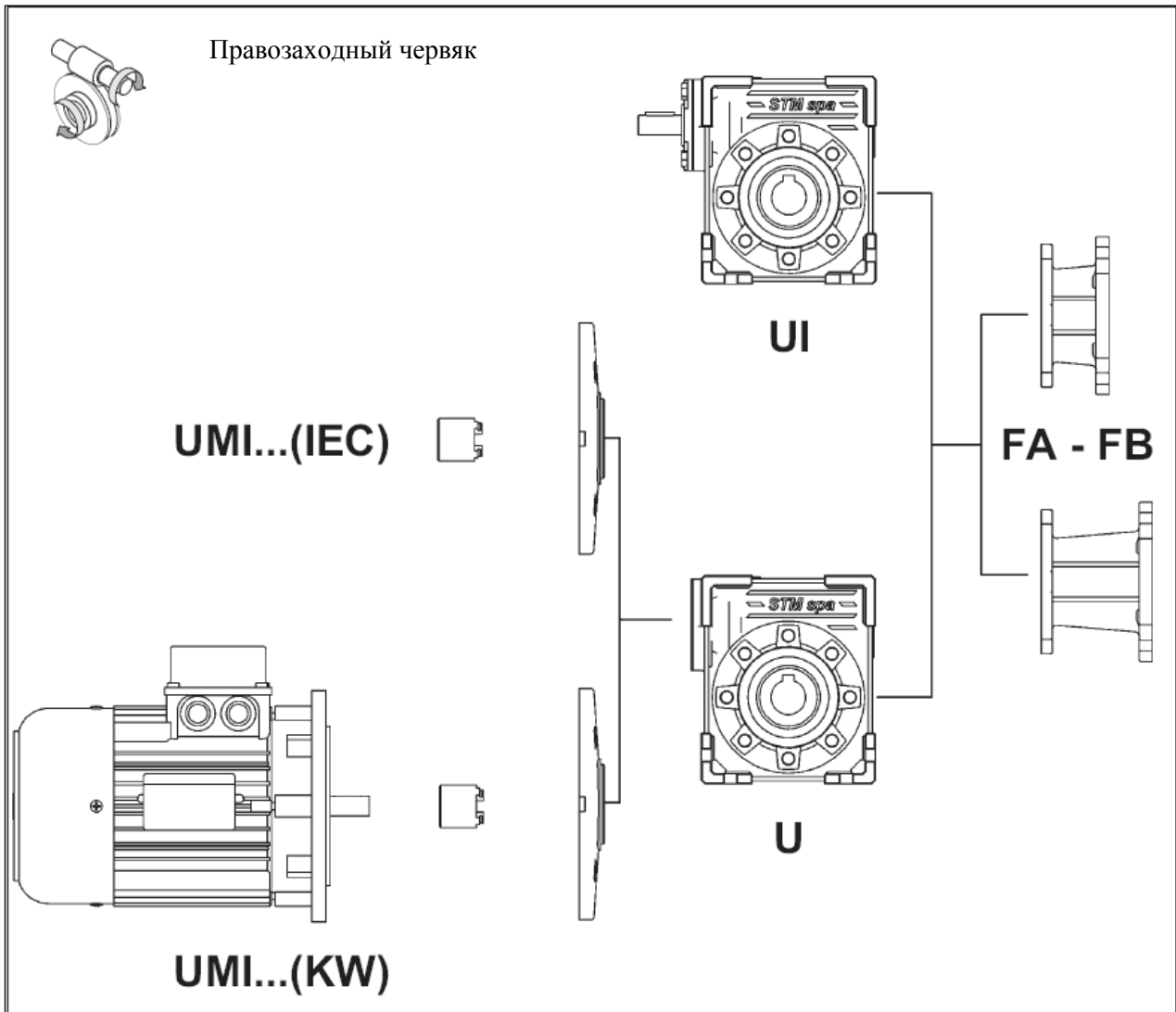

Стандарт

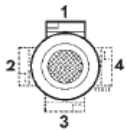

Положение клемной коробки



3.4 Смазка

Общая информация

Рекомендуется использовать синтетическое масло (см. Раздел 1, пункт 1.6 и 1.2). В таблицах 3.2.1 и 3.2.2 указан объем смазки, необходимый для надлежащей работы червячного редуктора.

Необходимость указания монтажного положения при заказе

Червячные редукторы размеров 40, 50, 63, 75 поставляются заправленные синтетическим маслом вязкостью 320 согласно ISO.

Монтажные положения UI-UMII





Таблица 3.2.1

U - UMI		Объем смазки (кг)						Состояние поставки	Кол-во пробок	Монтажное положение
	Монтажные положения									
	M1	M2	M3	M4	M5	M6				
40	0.100						Поставляются редукторы, заправленные синтетическим маслом	1	не обязательно	
50	0.150							1		
63	0.300							1		
75	0.600							1		
90	0.900							3		

Таблица 3.2.2

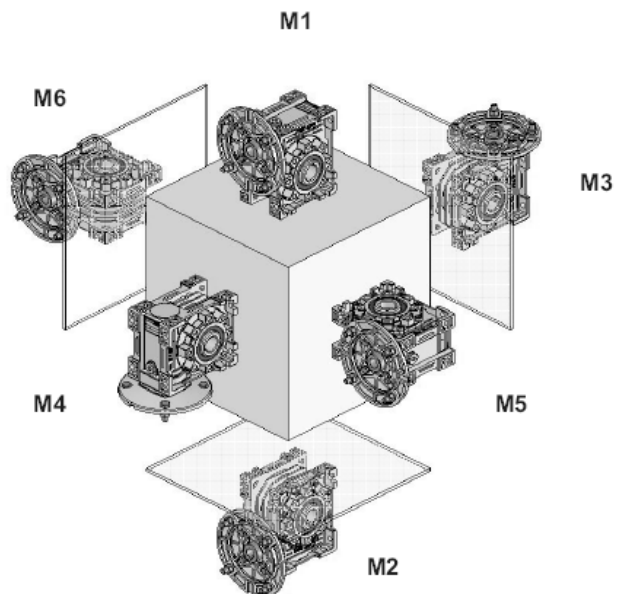
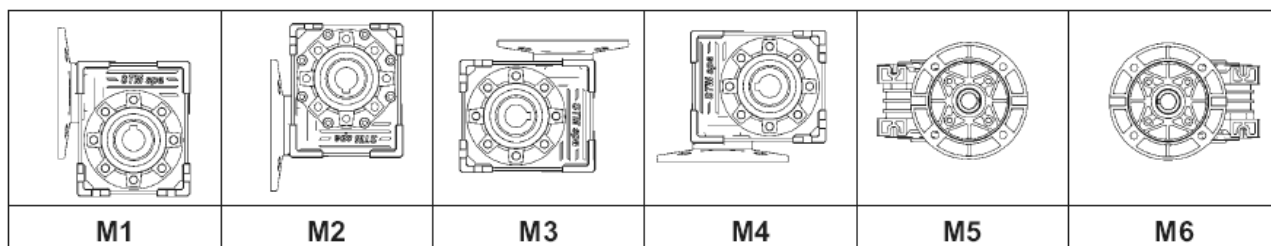
UI		Объем смазки (кг)						Состояние поставки	Кол-во пробок	Монтажное положение
	Монтажные положения									
	M1	M2	M3	M4	M5	M6				
40	0.100						Поставляются редукторы, заправленные синтетическим маслом	1	не обязательно	
50	0.190							1		
63	0.450							1		
75	0.600							1		
90	1.300							3		

А) Сапун устанавливается только на редукторы где количество пробок больше 1.

Б) Редукторы нестандартного монтажного положения имеют соответствующую маркировку на шильдике.



3.5 Осевые и радиальные нагрузки

Так как при передаче движения создаются радиальные нагрузки на конец вала необходимо проверить, чтобы результирующие значения не превышали значений, указанных в таблицах.

В Таблице 3.5 приведены допустимые значения радиальной нагрузки для входного вала (Fr_1). Допустимая осевая нагрузка определяется по следующей формуле:

$$Fa_1 = 0.2 \times Fr_1$$

Таблица 3.5



UI

n_1 МИН. ⁻¹	Fr_1 (Н)				
	UI				
	40	50	63	75	90
2800	187	272	357	510	700
1400	220	320	420	600	800
900	250	350	460	660	900
700	280	400	500	730	1000
500	310	450	530	800	1100

В таблице 3.7 приведены допустимые значения радиальной нагрузки для выходного вала (Fr_2). Допустимая осевая нагрузка определяется по следующей формуле:

$$Fa_2 = 0.2 \times Fr_2$$

Таблица 3.7

UI
UMI

n_2 МИН. ⁻¹	Fr_2 (Н)				
	UI - UMI				
	40	50	63	75	90
400	686	925	946	1400	1897
280	808	1088	1114	1700	2232
200	950	1280	1310	2000	2625
140	1050	1450	1680	2300	2775
93	1200	1620	1740	2600	3050
70	1350	1850	1930	2800	3400
50	1500	2100	2150	3400	4205
35	1600	2230	2300	3700	4775
29	1700	2400	2500	4100	5300
25	1800	2580	2700	4300	5610
20	1950	2700	2900	4700	6175
18	2100	2850	3100	4900	6650
14	2300	3200	3300	5200	7025

Для увеличения нагрузочной способности редуктора возможна установка выходного вала в конические роликовые подшипники. Такие усиленные модели поставляются по запросу.

В Таблице 3.9 приведены значения радиальной и осевой нагрузки на выходной вал, установленный в конические роликовые подшипники. Рекомендуем использовать модели с фланцевым креплением и убедиться, что осевая нагрузка поглощается подшипником, установленным в корпус глухого фланца.

Таблица 3.9



UI
UMI

ОСЕВЫЕ И РАДИАЛЬНЫЕ НАГРУЗКИ, СОЗДАВАЕМЫЕ ЧЕРВЯЧНЫМ КОЛЕСОМ ПРИ УСТАНОВКЕ ВАЛА В КОНИЧЕСКИЕ ПОДШИПНИКИ										
n ₂ (об./мин.)	UI - UMI									
	40		50		63		75		90	
	F _{r2}	F _{a2}	F _{r2}	F _{a2}	F _{r2}	F _{a2}	F _{r2}	F _{a2}		
400	2076	2708	4603	5325	4693	5415	5415	6588	6543	8529
280	2185	2850	4845	5605	4940	5700	5700	6935	6888	8978
200	2300	3000	5100	5900	5200	6000	6000	7300	7250	9450
140	2300	3000	5600	6500	5750	6650	6700	8200	7900	10300
93	2300	3000	6300	7300	6500	7550	7500	9150	8400	10950
70	2300	3000	6550	7600	6200	7200	7600	9300	7850	10225
50	2300	3000	6900	8000	6900	8000	8700	10600	9250	12050
35	2300	3000	6900	8000	6900	8000	9000	11000	11450	14900
29	2300	3000	6900	8000	6900	8000	9000	11000	11900	15500
25	2300	3000	6900	8000	6900	8000	9000	11000	11900	15500
20	2300	3000	6900	8000	6900	8000	9000	11000	11900	15500
18	2300	3000	6900	8000	6900	8000	9000	11000	11900	15500

Радиальные нагрузки, значения которых указаны в таблицах, приложены посередине выступающего конца вала и соответствуют редукторам, работающим с эксплуатационным коэффициентом, равным 1.

Величины частоты вращения, не указанные в таблице, могут быть вычислены с помощью интерполяции, но необходимо учитывать, что F_{r1} при 500 мин.⁻¹ и F_{r2} при 14 мин.⁻¹ являются максимально допустимыми нагрузками.

Величина нагрузки, прилагаемой не по середине выступающего конца вала, рассчитываются по следующей формуле:

на расстоянии 0,3 длины выступающего конца вала:

$$F_{rx} = 1.25 \times F_{r1-2}$$

на расстоянии 0,8 длины выступающего конца вала:

$$F_{rx} = 0.8 \times F_{r1-2}$$

Таблица 2.11

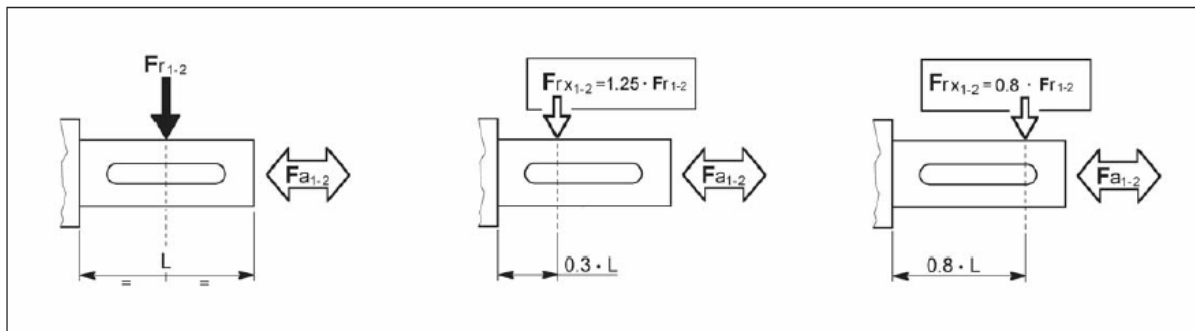



3.6 Эксплуатационные показатели редукторов серии UI

UI 40



2.1

ir	$n_1 = 2800 \text{ min}^{-1}$ ▲				$n_1 = 1400 \text{ min}^{-1}$				$n_1 = 900 \text{ min}^{-1}$				$n_1 = 500 \text{ min}^{-1}$				IEC
	n_2 min ⁻¹	T_{2M} Nm	P kW	RD %	n_2 min ⁻¹	T_{2M} Nm	P kW	RD %	n_2 min ⁻¹	T_{2M} Nm	P kW	RD %	n_2 min ⁻¹	T_{2M} Nm	P kW	RD %	
7	400	27	1.3	84	200	37	0.93	83	129	44	0.73	81	71	54	0.50	80	71-63-56
10	280	31	1.1	83	140	42	0.76	81	90	49	0.58	79	50	59	0.40	78	
15	187	32	0.78	80	93	42	0.53	77	60	49	0.41	75	33	59	0.28	73	
20	140	29	0.56	76	70	37	0.37	73	45	43	0.29	70	25	51	0.20	67	
28	100	34	0.50	71	50	43	0.34	67	32	50	0.26	64	17.9	59	0.18	61	
40	70	32	0.36	65	35	40	0.24	60	23	45	0.19	56	12.5	53	0.13	53	
49	57	30	0.29	62	29	38	0.20	57	18.4	43	0.16	53	10.2	50	0.11	49	
56	50	28	0.24	60	25	36	0.17	54	16.1	40	0.13	51	8.9	47	0.09	47	
70	40	23	0.18	53	20	28	0.12	47	12.9	32	0.10	44	7.1	37	0.07	39	
80	35	21	0.15	50	17.5	26	0.11	44	11.3	29	0.09	40	6.3	34	0.06	36	
100	28	23	0.13	51	14.0	28	0.09	45	9.0	30	0.07	41	5.0	31	0.04	38	

UI 50



3.5

ir	$n_1 = 2800 \text{ min}^{-1}$ ▲				$n_1 = 1400 \text{ min}^{-1}$				$n_1 = 900 \text{ min}^{-1}$				$n_1 = 500 \text{ min}^{-1}$				IEC
	n_2 min ⁻¹	T_{2M} Nm	P kW	RD %	n_2 min ⁻¹	T_{2M} Nm	P kW	RD %	n_2 min ⁻¹	T_{2M} Nm	P kW	RD %	n_2 min ⁻¹	T_{2M} Nm	P kW	RD %	
7	400	50	2.5	85	200	68	1.7	84	129	81	1.3	83	71	100	0.91	82	80-71-63
10	280	55	1.9	84	140	73	1.3	82	90	86	1.0	81	50	105	0.70	79	
15	187	58	1.4	82	93	76	0.93	80	60	89	0.71	79	33	106	0.48	77	
20	140	57	1.1	79	70	74	0.71	76	45	86	0.55	74	25	102	0.38	71	
28	100	62	0.88	74	50	80	0.60	70	32	92	0.46	67	17.9	109	0.32	64	
40	70	64	0.67	70	35	81	0.45	66	23	92	0.34	63	12.5	108	0.24	59	
49	57	57	0.51	67	29	72	0.34	63	18.4	82	0.27	59	10.2	96	0.19	55	
56	50	55	0.44	65	25	69	0.30	60	16.1	78	0.23	56	8.9	91	0.16	53	
70	40	52	0.36	61	20	64	0.24	56	12.9	72	0.19	52	7.1	84	0.13	48	
80	35	47	0.30	57	17.5	58	0.21	51	11.3	66	0.17	47	6.3	75	0.11	43	
100	28	42	0.23	54	14.0	52	0.16	48	9.0	59	0.13	44	5.0	60	0.08	40	

UI 63



6.0

ir	$n_1 = 2800 \text{ min}^{-1}$ ▲				$n_1 = 1400 \text{ min}^{-1}$				$n_1 = 900 \text{ min}^{-1}$				$n_1 = 500 \text{ min}^{-1}$				IEC
	n_2 min ⁻¹	T_{2M} Nm	P kW	RD %	n_2 min ⁻¹	T_{2M} Nm	P kW	RD %	n_2 min ⁻¹	T_{2M} Nm	P kW	RD %	n_2 min ⁻¹	T_{2M} Nm	P kW	RD %	
7	400	84	4.1	86	200	115	2.9	84	129	137	2.2	84	71	169	1.5	83	90-80-71
10	280	93	3.2	84	140	126	2.2	83	90	149	1.7	81	50	182	1.2	80	
15	187	98	2.3	82	93	131	1.6	80	60	153	1.2	78	33	184	0.85	76	
20	140	104	1.9	80	70	136	1.3	77	45	158	0.99	75	25	189	0.69	72	
28	100	105	1.5	75	50	135	1.0	71	32	156	0.77	68	17.9	186	0.54	65	
40	70	113	1.2	71	35	145	0.79	67	23	166	0.61	64	12.5	195	0.43	60	
49	57	98	0.85	69	29	125	0.58	64	18.4	142	0.45	61	10.2	166	0.31	57	
56	50	101	0.79	67	25	127	0.54	62	16.1	145	0.42	58	8.9	169	0.29	54	
70	40	94	0.62	63	20	117	0.42	58	12.9	133	0.33	54	7.1	154	0.23	50	
80	35	88	0.53	61	17.5	110	0.37	55	11.3	124	0.29	51	6.3	144	0.20	47	
100	28	80	0.41	57	14.0	99	0.28	51	9.0	112	0.22	47	5.0	125	0.15	43	



UI 75

Kg 9.0

ir	$n_1 = 2800 \text{ min}^{-1}$				$n_1 = 1400 \text{ min}^{-1}$				$n_1 = 900 \text{ min}^{-1}$				$n_1 = 500 \text{ min}^{-1}$				IEC
	n_2 min ⁻¹	T_{2M} Nm	P kW	RD %	n_2 min ⁻¹	T_{2M} Nm	P kW	RD %	n_2 min ⁻¹	T_{2M} Nm	P kW	RD %	n_2 min ⁻¹	T_{2M} Nm	P kW	RD %	
7	400	146	7,11	86	200	205	5,05	85	129	241	3,86	84	71	298	2,69	83	100-112 ⁽¹⁾ 90-80
10	280	163	5,66	85	140	220	3,86	84	90	261	2,98	83	50	320	2,08	81	
15	187	173	4,12	82	93	230	2,79	81	60	270	2,16	79	33	325	1,48	77	
20	140	161	2,93	81	70	220	2,07	78	45	245	1,52	76	25	293	1,05	73	
28	100	193	2,71	75	50	255	1,87	72	32	290	1,42	69	18	345	1,00	65	
40	70	176	1,80	72	35	230	1,24	68	23	258	0,94	65	13	303	0,65	61	
49	57	169	1,47	69	29	220	1,02	65	18	245	0,77	61	10	287	0,54	57	
56	50	153	1,17	69	25	200	0,82	64	16	219	0,61	60	9	256	0,43	56	
70	40	153	1,00	64	20	195	0,69	59	13	217	0,53	56	7	252	0,37	51	
80	35	145	0,86	62	18	185	0,61	56	11	205	0,46	52	6	237	0,32	48	
100	28	131	0,66	59	14	170	0,48	52	9	183	0,36	49	5	206	0,25	44	

UI 90

Kg 14.0

ir	$n_1 = 2800 \text{ min}^{-1}$				$n_1 = 1400 \text{ min}^{-1}$				$n_1 = 900 \text{ min}^{-1}$				$n_1 = 500 \text{ min}^{-1}$				IEC
	n_2 min ⁻¹	T_{2M} Nm	P kW	RD %	n_2 min ⁻¹	T_{2M} Nm	P kW	RD %	n_2 min ⁻¹	T_{2M} Nm	P kW	RD %	n_2 min ⁻¹	T_{2M} Nm	P kW	RD %	
7	400	230	11,2	86	200	320	7,8	86	129	382	6,1	85	71	474	4,2	84	100-112 ⁽¹⁾ 90-80
10	280	255	8,8	85	140	347	6,0	85	90	412	4,6	84	50	505	3,2	82	
15	187	278	6,6	83	93	371	4,4	82	60	436	3,4	80	33	526	2,4	78	
20	140	290	5,2	82	70	381	3,5	80	45	444	2,7	78	25	531	1,9	75	
28	100	318	4,4	76	50	414	2,9	74	32	480	2,3	71	18	572	1,6	67	
40	70	316	3,2	73	35	406	2,1	71	23	466	1,6	67	13	550	1,1	64	
49	57	290	2,4	71	29	368	1,6	67	18	421	1,3	64	10	494	0,9	60	
56	50	272	2,0	71	25	344	1,3	68	16	392	1,0	63	9	458	0,7	59	
70	40	246	1,5	67	20	309	1,0	63	13	350	0,8	59	7	408	0,6	54	
80	35	238	1,4	65	18	297	0,9	60	11	336	0,7	56	6	390	0,5	52	
100	28	217	1,1	61	14	270	0,7	55	9	296	0,5	52	5	313	0,4	47	

ВНИМАНИЕ!

В случае нестандартной входной частоты вращения руководствуйтесь данными приведенной ниже таблицы, в которой учтены предельные условия эксплуатации для каждого редуктора (См. раздел 1.2).

	UI - RI											
	28	40	50	63	70	75	85	90	110	130	150	180
$1500 < n_1 < 3000$	OK	OK	OK									
$n_1 > 3000$	Обращайтесь в наш технический отдел											

⁽¹⁾ ВНИМАНИЕ!

Чертеж шпонки фирмы STM
(См. Раздел 1.11)

Значения веса, указанные в таблицах, являются ориентировочными и могут изменяться в зависимости от модели редуктора.

ПРИМЕЧАНИЕ.

Обратите внимание на значения входной мощности, выделенные в рамку: для данных редукторов необходимо проверять тепловой режим работы (см. Раздел 1.7). Для получения дополнительной информации обращайтесь в наш технический отдел.



В таблице 3.6 указаны IEC размеры, а так же возможные комбинации вал/фланец для присоединения двигателя к редуктору.

Possibili accoppiamenti con motori IEC / Possible couplings with IEC motors / Mögliche Verbindungen mit IEC-Motoren.												
	IEC	ir										
		7	10	15	20	28	40	49	56	70	80	100
UMI 40	71 ⁽¹⁾	14/160 (B5) - 14/105 (B14) - 14/140 - 14/120 - 14/90•										
	63	11/140 (B5) - 11/90• (B14) - 11/160 - 11/120 - 11/105										
	56	9/120 (B5) - 9/160 - 9/140 - 9/105 - 9/90•										
UMI 50	80 ⁽¹⁾	19/120 (B14) - 19/200 (B5) - 19/160 - 19/140 - 19/105• - 19/90•										
	71	14/160 (B5) - 14/105• (B14) - 14/200 - 14/140 - 14/120 - 14/90•										
	63	11/140 (B5) - 11/90• (B14) - 11/200 - 11/160 - 11/120 - 11/105•										
UMI 63	90 ⁽¹⁾	24/200 (B5) - 24/140 (B14) - 24/160 - 24/120 - 24/105•										
	80	19/200 (B5) - 19/120 (B14) - 19/160 - 19/140 - 19/105•										
	71	14/160 (B5) - 14/105• (B14) - 14/200 - 14/140 - 14/120										
UMI 75	112 ⁽¹⁾	28/250 (B5) - 28/160 (B14) 28/140										
	100 ⁽¹⁾	28/250 (B5) - 28/160 (B14) 28/140										
	90	24/200 (B5) - 24/140 (B14) - 24/250 - 24/160 - 24/120										
	80	19/200 (B5) - 19/120 (B14) - 19/250 - 19/160 - 19/140										
UMI 90	112 ⁽¹⁾	28/250 (B5) - 28/160 (B14)										
	100 ⁽¹⁾	28/250 (B5) - 28/160 (B14)										
	90	24/200 (B5) - 24/140 (B14) - 24/250 - 24/160 - 24/120										
	80	19/200 (B5) - 19/120 (B14) - 19/250 - 19/160 - 19/140										

Таблица 3.6

⁽¹⁾ **ВНИМАНИЕ!**

Чертеж шпонки фирмы STM
(См. Раздел 1.11)

Пример расшифровки обозначений:

11/140 (B5) 11/120

11/140: стандартная комбинация вал/фланец

(B5): конструкция двигателя IEC

11/120: комбинации вал/фланец, поставляемые по запросу

Примечание.

В стандартной конфигурации 4 отверстия расположены под углом 45° по отношению к осям (х-образно: см. Раздел 2.3).

Для фланцев B14, отмеченных знаком (•), отверстия для установки двигателя расположены на осях (+-образно). Мы рекомендуем поверять размеры клеммной коробки двигателя, как если бы она устанавливалась под углом 45° к осям. Выберите положение клеммной коробки согласно следующему чертежу (на котором № 5 – стандартное положение):

СТАНДАРТНОЕ

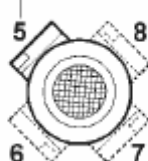



3.7 Эксплуатационные показатели мотор - редукторов

n_2 min ⁻¹	ir	T2 Nm	FS'		
----------------------------	----	----------	-----	--	--

0.09 kW	$n_1= 2740 \text{ min}^{-1}$ $n_1= 1360 \text{ min}^{-1}$ $n_1= 860 \text{ min}^{-1}$	56A 2 56B 4 63B 6
----------------	---	-------------------------

49	28	12	3.6	UMI 40	56B 4
43	20	14	3.1	UMI 40	63B 6
34	40	15	2.6	UMI 40	56B 4
31	28	18	2.8	UMI 40	63B 6
28	49	18	2.2	UMI 40	56B 4
24	56	19	1.9	UMI 40	56B 4
19.4	70	21	1.3	UMI 40	56B 4
17.0	80	22	1.2	UMI 40	56B 4
15.4	56	29	1.4	UMI 40	63B 6
13.6	100	28	1.0	UMI 40	56B 4
12.3	70	31	1.0	UMI 40	63B 6

0.11 kW	$n_1= 1360 \text{ min}^{-1}$	56C 4
----------------	------------------------------	-------

68	20	11	3.3	UMI 40	56C 4
49	28	14	3.0	UMI 40	56C 4
34	40	19	2.2	UMI 40	56C 4
28	49	22	1.8	UMI 40	56C 4
24	56	23	1.5	UMI 40	56C 4
19.4	70	25	1.1	UMI 40	56C 4
17.0	80	27	1.0	UMI 40	56C 4
13.6	100	35	0.8	UMI 40	56C 4

0.13 kW	$n_1= 2750 \text{ min}^{-1}$ $n_1= 1360 \text{ min}^{-1}$ $n_1= 860 \text{ min}^{-1}$	56B 2 63A 4 63C 6
----------------	---	-------------------------

393	7	3	10.2	UMI 40	56B 2
393	7	3	9.8	UMI 40	56B 2
275	10	4	8.3	UMI 40	56B 2
275	10	4	8.0	UMI 40	56B 2
194	7	5	7.0	UMI 40	63A 4
136	10	7	5.7	UMI 40	63A 4
91	15	11	4.0	UMI 40	63A 4
68	20	13	2.8	UMI 40	63A 4
56	49	14	2.2	UMI 40	56B 2
56	49	14	2.1	UMI 40	56B 2
49	28	17	2.5	UMI 40	63A 4
34	40	24	3.4	UMI 50	63A 4
34	40	22	1.8	UMI 40	63A 4
28	49	28	2.6	UMI 50	63A 4
28	49	25	1.5	UMI 40	63A 4
24	56	31	2.2	UMI 50	63A 4
24	56	28	1.3	UMI 40	63A 4
22	40	36	2.5	UMI 50	63C 6
22	40	32	1.4	UMI 40	63C 6
19.4	70	36	1.8	UMI 50	63A 4
19.4	70	30	0.9	UMI 40	63A 4
17.0	80	37	1.6	UMI 50	63A 4
17.0	80	32	0.8	UMI 40	63A 4
13.6	100	44	1.2	UMI 50	63A 4
12.3	70	53	1.4	UMI 50	63C 6
8.6	100	64	0.9	UMI 50	63C 6

n_2 min ⁻¹	ir	T2 Nm	FS'		
----------------------------	----	----------	-----	--	--

0.18 kW	$n_1= 2760 \text{ min}^{-1}$ $n_1= 1370 \text{ min}^{-1}$ $n_1= 870 \text{ min}^{-1}$	63A 2 63B 4 71A 6
----------------	---	-------------------------

394	7	4	7.4	UMI 40	63A 2
276	10	5	6.0	UMI 40	63A 2
196	7	7	5.1	UMI 40	63B 4
137	10	10	4.1	UMI 40	63B 4
124	7	11	3.9	UMI 40	71A 6
91	15	14	2.9	UMI 40	63B 4
69	20	18	2.0	UMI 40	63B 4
58	15	22	2.2	UMI 40	71A 6
49	28	25	3.3	UMI 50	63B 4
49	28	24	1.8	UMI 40	63B 4
44	20	29	2.9	UMI 50	71A 6
44	20	28	1.6	UMI 40	71A 6
34	40	33	2.4	UMI 50	63B 4
34	40	30	1.3	UMI 40	63B 4
28	49	39	1.9	UMI 50	63B 4
28	49	35	1.1	UMI 40	63B 4
24	56	42	1.6	UMI 50	63B 4
24	56	38	0.9	UMI 40	63B 4
19.6	70	49	1.3	UMI 50	63B 4
17.1	80	51	1.1	UMI 50	63B 4
15.5	56	64	2.3	UMI 63	71A 6
15.5	56	62	1.3	UMI 50	71A 6
13.7	100	60	0.9	UMI 50	63B 4
12.4	70	75	1.8	UMI 63	71A 6
12.4	70	72	1.0	UMI 50	71A 6
10.9	80	81	1.5	UMI 63	71A 6
10.9	80	74	0.9	UMI 50	71A 6
8.7	100	93	1.2	UMI 63	71A 6

0.22 kW	$n_1= 1400 \text{ min}^{-1}$	63C 4
----------------	------------------------------	-------

200	7	9	4.2	UMI 40	63C 4
140	10	12	3.5	UMI 40	63C 4
93	15	17	2.4	UMI 40	63C 4
70	20	22	1.7	UMI 40	63C 4
50	28	29	2.7	UMI 50	63C 4
50	28	28	1.5	UMI 40	63C 4
35	40	40	2.0	UMI 50	63C 4
35	40	36	1.1	UMI 40	63C 4
29	49	46	1.6	UMI 50	63C 4
29	49	42	0.9	UMI 40	63C 4
25	56	50	1.4	UMI 50	63C 4
20	70	59	1.1	UMI 50	63C 4
17.5	80	61	0.9	UMI 50	63C 4

n_2 min ⁻¹	ir	T2 Nm	FS'		
----------------------------	----	----------	-----	--	--

0.25 kW	$n_1= 2790 \text{ min}^{-1}$ $n_1= 1370 \text{ min}^{-1}$ $n_1= 870 \text{ min}^{-1}$	63B 2 71A 4 71B 6
----------------	---	-------------------------

399	7	5	5.4	UMI 40	63B 2
399	7	5	5.4	UMI 40	63B 2
279	10	7	4.4	UMI 40	63B 2
196	7	10	6.6	UMI 50	71A 4
196	7	10	3.7	UMI 40	71A 4
137	10	14	5.1	UMI 50	71A 4
137	10	14	3.0	UMI 40	71A 4
124	7	16	5.1	UMI 50	71B 6
124	7	16	2.8	UMI 40	71B 6
91	15	21	3.6	UMI 50	71A 4
91	15	20	2.1	UMI 40	71A 4
69	20	26	2.8	UMI 50	71A 4
69	20	25	1.5	UMI 40	71A 4
58	15	33	2.7	UMI 50	71B 6
58	15	31	1.6	UMI 40	71B 6
49	28	34	2.3	UMI 50	71A 4
49	28	33	1.3	UMI 40	71A 4
44	20	41	2.1	UMI 50	71B 6
44	20	38	1.1	UMI 40	71B 6
34	40	47	3.1	UMI 63	71A 4
34	40	46	1.8	UMI 50	71A 4
31	28	52	3.0	UMI 63	71B 6
31	28	51	1.8	UMI 50	71B 6
31	28	49	1.0	UMI 40	71B 6
28	49	55	2.3	UMI 63	71A 4
28	49	54	1.3	UMI 50	71A 4
24	56	61	2.1	UMI 63	71A 4
24	56	59	1.2	UMI 50	71A 4
22	40	70	2.4	UMI 63	71B 6
22	40	69	1.3	UMI 50	71B 6
19.6	70	71	1.7	UMI 63	71A 4
19.6	70	68	0.9	UMI 50	71A 4
17.1	80	77	1.4	UMI 63	71A 4
17.1	80	71	0.8	UMI 50	71A 4
15.5	56	89	1.6	UMI 63	71B 6
15.5	56	86	0.9	UMI 50	71B 6
13.7	100	89	1.1	UMI 63	71A 4
12.4	70	104	1.3	UMI 63	71B 6

0.37 kW	$n_1= 2790 \text{ min}^{-1}$ $n_1= 2790 \text{ min}^{-1}$ $n_1= 1380 \text{ min}^{-1}$ $n_1= 910 \text{ min}^{-1}$	63C 2 71A 2 71B 4 80A 6
----------------	---	----------------------------------

399	7	7	3.6	UMI 40	71A 2
399	7	7	3.6	UMI 40	63C 2
279	10	11	2.9	UMI 40	71A 2
279	10	11	2.9	UMI 40	63C 2
197	7	15	4.5	UMI 50	71B 4
197	7	15	2.5	UMI 40	71B 4
186	15	16	3.7	UMI 50	71A 2
186	15	15	2.1	UMI 40	71A 2
186	15	15	2.1	UMI 40	63C 2
140	20	20	2.8	UMI 50	71A 2
140	20	19	1.5	UMI 40	71A 2



STANDARD *line*

n_2 min ⁻¹	ir	T2 Nm	FS'		
----------------------------	----	----------	-----	--	--

0.37 kW

$n_1 = 2790 \text{ min}^{-1}$	63C 2
$n_1 = 2790 \text{ min}^{-1}$	71A 2
$n_1 = 1380 \text{ min}^{-1}$	71B 4
$n_1 = 910 \text{ min}^{-1}$	80A 6

140	20	19	1.5	UMI 40	63C 2
138	10	21	3.5	UMI 50	71B 4
138	10	21	2.0	UMI 40	71B 4
92	15	31	2.5	UMI 50	71B 4
92	15	30	1.4	UMI 40	71B 4
61	15	46	5.7	UMI 75	80A 6
69	20	39	3.4	UMI 63	71B 4
69	20	39	1.9	UMI 50	71B 4
69	20	37	1.0	UMI 40	71B 4
49	28	51	2.7	UMI 63	71B 4
49	28	50	1.6	UMI 50	71B 4
49	28	48	0.9	UMI 40	71B 4
35	40	69	2.1	UMI 63	71B 4
45	20	60	3.9	UMI 75	80A 6
35	40	68	1.2	UMI 50	71B 4
33	28	76	3.7	UMI 75	80A 6
28	49	80	1.6	UMI 63	71B 4
28	49	79	0.9	UMI 50	71B 4
25	56	89	1.4	UMI 63	71B 4
25	56	86	0.8	UMI 50	71B 4
23	40	104	4.5	UMI 90	80A 6
23	40	104	2.4	UMI 75	80A 6
20	70	104	1.1	UMI 63	71B 4
19	49	122	3.5	UMI 90	80A 6
19	49	120	2.0	UMI 75	80A 6
17	80	113	1.0	UMI 63	71B 4
16	56	137	2.9	UMI 90	80A 6
16	56	135	1.6	UMI 75	80A 6
13	70	160	2.2	UMI 90	80A 6
13	70	155	1.4	UMI 75	80A 6
11	80	174	1.9	UMI 90	80A 6
11	80	171	1.2	UMI 75	80A 6
9	100	202	1.5	UMI 90	80A 6
9	100	198	0.9	UMI 75	80A 6

0.55 kW

$n_1 = 2800 \text{ min}^{-1}$	71B 2
$n_1 = 1380 \text{ min}^{-1}$	71C 4
$n_1 = 1390 \text{ min}^{-1}$	80A 4
$n_1 = 910 \text{ min}^{-1}$	80B 6

400	7	11	4.5	UMI 50	71B 2
400	7	11	2.4	UMI 40	71B 2
280	10	16	3.5	UMI 50	71B 2
280	10	16	2.0	UMI 40	71B 2
199	7	22	3.1	UMI 50	80A 4
197	7	22	3.0	UMI 50	71C 4
197	7	22	1.7	UMI 40	71C 4
187	15	23	1.4	UMI 40	71B 2
140	20	29	1.0	UMI 40	71B 2
139	10	32	7.0	UMI 75	80A 4
139	10	31	2.4	UMI 50	80A 4
138	10	31	2.3	UMI 50	71C 4
138	10	31	1.4	UMI 40	71C 4
130	7	34	7.0	UMI 75	80B 6

n_2 min ⁻¹	ir	T2 Nm	FS'		
----------------------------	----	----------	-----	--	--

0.55 kW

$n_1 = 2800 \text{ min}^{-1}$	71B 2
$n_1 = 1380 \text{ min}^{-1}$	71C 4
$n_1 = 1390 \text{ min}^{-1}$	80A 4
$n_1 = 910 \text{ min}^{-1}$	80B 6

130	7	34	2.4	UMI 50	80B 6
100	28	39	2.7	UMI 63	71B 2
100	28	39	1.6	UMI 50	71B 2
93	15	46	5.0	UMI 75	80A 4
93	15	45	2.9	UMI 63	80A 4
93	15	45	1.7	UMI 50	80A 4
92	15	46	1.7	UMI 50	71C 4
92	15	44	1.0	UMI 40	71C 4
70	20	60	3.7	UMI 75	80A 4
70	20	58	2.3	UMI 63	80A 4
70	20	57	1.3	UMI 50	80A 4
69	20	58	1.3	UMI 50	71C 4
61	15	69	6.3	UMI 90	80B 6
61	15	68.4	3.8	UMI 75	80B 6
50	28	78	5.3	UMI 90	80A 4
50	28	76	3.3	UMI 75	80A 4
50	28	75	1.8	UMI 63	80A 4
50	28	74	1.1	UMI 50	80A 4
49	28	76	1.8	UMI 63	71C 4
49	28	75	1.1	UMI 50	71C 4
46	20	90	4.9	UMI 90	80B 6
46	20	88	2.6	UMI 75	80B 6
46	20	87	1.8	UMI 63	80B 6
46	20	85	1.0	UMI 50	80B 6
35	40	107	3.8	UMI 90	80A 4
35	40	102	2.2	UMI 75	80A 4
35	40	101	1.4	UMI 63	80A 4
35	40	102	1.4	UMI 63	71C 4
35	40	100	0.8	UMI 50	71C 4
28	49	124	3.0	UMI 90	80A 4
28	49	120	1.8	UMI 75	80A 4
28	49	119	1.1	UMI 63	80A 4
28	49	119	1.0	UMI 63	71C 4
25	56	144	2.4	UMI 90	80A 4
25	56	138	1.5	UMI 75	80A 4
25	56	131	1.0	UMI 63	80A 4
25	56	132	1.0	UMI 63	71C 4
20	70	167	1.9	UMI 90	80A 4
20	70	161	1.2	UMI 75	80A 4
19	49	181	2.3	UMI 90	80B 6
19	49	178	1.4	UMI 75	80B 6
17	80	181	1.6	UMI 90	80A 4
17	80	178	1.0	UMI 75	80A 4
16	56	204	1.9	UMI 90	80B 6
16	56	200	1.0	UMI 75	80B 6
14	100	208	1.3	UMI 90	80A 4
14	100	208	0.8	UMI 75	80A 4
13	70	238	1.5	UMI 90	80B 6
13	70	230	0.9	UMI 75	80B 6
11	80	259	1.3	UMI 90	80B 6
11	80	254	0.8	UMI 75	80B 6
9	100	300	1.0	UMI 90	80B 6

n_2 min ⁻¹	ir	T2 Nm	FS'		
----------------------------	----	----------	-----	--	--

0.75 kW

$n_1 = 2820 \text{ min}^{-1}$	71C 2
$n_1 = 2820 \text{ min}^{-1}$	80A 2
$n_1 = 1390 \text{ min}^{-1}$	80B 4
$n_1 = 910 \text{ min}^{-1}$	80C 6
$n_1 = 920 \text{ min}^{-1}$	90S 6

403	7	15	3.3	UMI 50	80A 2
400	7	15	3.3	UMI 50	71C 2
282	10	21	2.6	UMI 50	80A 2
280	10	21	2.6	UMI 50	71C 2
199	7	31	6.7	UMI 75	80B 4
199	7	30	3.8	UMI 63	80B 4
199	7	30	2.2	UMI 50	80B 4
139	10	43	5.1	UMI 75	80B 4
139	10	43	2.9	UMI 63	80B 4
139	10	42	1.7	UMI 50	80B 4
131	7	46	5.1	UMI 75	90S 6
131	7	46	3.0	UMI 63	90S 6
101	28	55	3.4	UMI 75	80A 2
101	28	53	2.0	UMI 63	80A 2
101	28	53	1.2	UMI 50	80A 2
100	28	54	2.0	UMI 63	71C 2
100	28	53	1.2	UMI 50	71C 2
93	15	63	3.7	UMI 75	80B 4
93	15	62	2.1	UMI 63	80B 4
93	15	62	1.2	UMI 50	80B 4
70	20	82	4.6	UMI 90	80B 4
70	20	81	2.7	UMI 75	80B 4
70	20	79	1.7	UMI 63	80B 4
70	20	78	0.9	UMI 50	80B 4
50	28	107	3.9	UMI 90	80B 4
50	28	103	2.4	UMI 75	80B 4
50	28	102	1.3	UMI 63	80B 4
35	40	146	2.8	UMI 90	80B 4
35	40	139	1.6	UMI 75	80B 4
35	40	138	1.0	UMI 63	80B 4
28	49	169	2.2	UMI 90	80B 4
28	49	169	1.3	UMI 75	80B 4
25	56	196	1.8	UMI 90	80B 4
25	56	188	1.1	UMI 75	80B 4
23	40	211	2.2	UMI 90	80C 6
23	40	211	1.2	UMI 75	80C 6
20	70	227	1.4	UMI 90	80B 4
20	70	220	0.9	UMI 75	80B 4
19	49	247	1.7	UMI 90	80C 6
19	49	243	1.0	UMI 75	80C 6
17	80	247	1.2	UMI 90	80B 4
17	80	243	0.8	UMI 75	80B 4
16	56	278	1.4	UMI 90	80C 6
16	56	273	0.8	UMI 75	80C 6
14	100	283	1.0	UMI 90	80B 4
13	70	325	1.1	UMI 90	80C 6
11	80	353	1.0	UMI 90	80C 6
9	100	409	0.7	UMI 90	80C 6



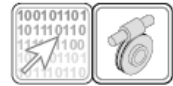

n_2 min ⁻¹	ir	T2 Nm	FS'		
----------------------------	----	----------	-----	--	--

0.88 kW

$n_1 = 1350 \text{ min}^{-1}$

80C 4

193	7	37	5.5	UMI 75	80C 4
193	7	37	3.1	UMI 63	80C 4
193	7	37	1.9	UMI 50	80C 4
135	10	52	4.2	UMI 75	80C 4
135	10	52	2.4	UMI 63	80C 4
135	10	51	1.4	UMI 50	80C 4
90	15	75	3.0	UMI 75	80C 4
90	15	75	1.8	UMI 63	80C 4
90	15	75	1.0	UMI 50	80C 4
68	20	100	3.8	UMI 90	80C 4
68	20	98	2.2	UMI 75	80C 4
68	20	96	1.4	UMI 63	80C 4
48	28	129	3.2	UMI 90	80C 4
48	28	125	2.0	UMI 75	80C 4
48	28	124	1.1	UMI 63	80C 4
34	40	177	2.3	UMI 90	80C 4
34	40	168	1.3	UMI 75	80C 4
34	40	167	0.9	UMI 63	80C 4
28	49	204	1.1	UMI 75	80C 4
28	49	204	1.8	UMI 90	80C 4
24	56	227	0.9	UMI 75	80C 4
24	56	237	1.5	UMI 90	80C 4
19	70	266	0.7	UMI 75	80C 4
19	70	275	1.1	UMI 90	80C 4
17	80	299	1.0	UMI 90	80C 4
14	100	342	0.8	UMI 90	80C 4

1.1 kW

$n_1 = 2830 \text{ min}^{-1}$
 $n_1 = 1390 \text{ min}^{-1}$
 $n_1 = 1400 \text{ min}^{-1}$
 $n_1 = 920 \text{ min}^{-1}$

80B 2
80D 4
90S 4
90L 6

404	7	22	6.4	UMI 75	80B 2
404	7	22	3.8	UMI 63	80B 2
404	7	22	2.3	UMI 50	80B 2
283	10	32	5.0	UMI 75	80B 2
283	10	31	3.0	UMI 63	80B 2
283	10	31	1.8	UMI 50	80B 2
200	7	45	4.6	UMI 75	90S 4
200	7	44	2.6	UMI 63	90S 4
199	7	45	4.6	UMI 75	80D 4
199	7	44	2.6	UMI 63	80D 4
189	15	46	3.7	UMI 75	80B 2
189	15	46	2.1	UMI 63	80B 2
189	15	46	1.3	UMI 50	80B 2
142	20	60	2.6	UMI 75	80B 2
142	20	59	1.0	UMI 50*	80B 2
140	10	63	3.5	UMI 75	80D 4
140	10	62	2.0	UMI 63	90S 4
139	10	64	5.4	UMI 90	80D 4
139	10	63	3.5	UMI 75	80D 4

n_2 min ⁻¹	ir	T2 Nm	FS'		
----------------------------	----	----------	-----	--	--

1.1 kW

$n_1 = 2830 \text{ min}^{-1}$
 $n_1 = 1390 \text{ min}^{-1}$
 $n_1 = 1400 \text{ min}^{-1}$
 $n_1 = 920 \text{ min}^{-1}$

80B 2
80D 4
90S 4
90L 6

139	10	63	2.0	UMI 63	80D 4
139	10	62	1.2	UMI 50	80D 4
131	7	68	5.6	UMI 90	90L 6
131	7	67	3.5	UMI 75	90L 6
131	7	67	2.0	UMI 63	90L 6
93	15	93	4.0	UMI 90	80D 4
93	15	91	2.5	UMI 75	80D 4
93	15	90	1.5	UMI 63	90S 4
93	15	91	1.4	UMI 63	80D 4
93	15	91	0.8	UMI 50	80D 4
70	20	121	3.2	UMI 90	80D 4
70	20	118	1.9	UMI 75	80D 4
70	20	116	1.2	UMI 63	90S 4
70	20	116	1.2	UMI 63	80D 4
61	15	137	3.2	UMI 90	90L 6
61	15	135	1.9	UMI 75	90L 6
61	15	134	1.1	UMI 63	90L 6
50	28	157	2.6	UMI 90	80D 4
50	28	150	1.6	UMI 75	80D 4
50	28	149	0.9	UMI 63	90S 4
50	28	150	0.9	UMI 63	80D 4
46	20	178	2.5	UMI 90	90L 6
46	20	172	1.3	UMI 75	90L 6
46	20	171	0.9	UMI 63	90L 6
25	56	286	1.2	UMI 90	90S 4
25	56	288	1.2	UMI 90	80D 4
23	40	306	0.8	UMI 75	90L 6
23	40	306	1.5	UMI 90	90L 6
20	70	331	0.9	UMI 90	90S 4
20	70	333	0.9	UMI 90	80D 4
19	49	358	1.2	UMI 90	90L 6
18	80	360	0.8	UMI 90	90S 4
17	80	363	0.8	UMI 90	80D 4
16	56	403	1.0	UMI 90	90L 6

1.5 kW

$n_1 = 2830 \text{ min}^{-1}$
 $n_1 = 2830 \text{ min}^{-1}$
 $n_1 = 1400 \text{ min}^{-1}$
 $n_1 = 925 \text{ min}^{-1}$
 $n_1 = 940 \text{ min}^{-1}$

80C 2
90S 2
90L 4
90LB 6
100A 6

404	7	30	7.5	UMI 90	90S 2
404	7	31	4.7	UMI 75	90S 2
404	7	31	4.7	UMI 75	80C 2
404	7	30	2.8	UMI 63	90S 2
404	7	30	2.8	UMI 63	80C 2
283	10	43	5.9	UMI 90	90S 2
283	10	43	3.7	UMI 75	90S 2
283	10	43	3.7	UMI 75	80C 2
283	10	43	2.2	UMI 63	90S 2
283	10	43	2.2	UMI 63	80C 2

n_2 min ⁻¹	ir	T2 Nm	FS'		
----------------------------	----	----------	-----	--	--

1.5 kW

$n_1 = 2830 \text{ min}^{-1}$
 $n_1 = 2830 \text{ min}^{-1}$
 $n_1 = 1400 \text{ min}^{-1}$
 $n_1 = 925 \text{ min}^{-1}$
 $n_1 = 940 \text{ min}^{-1}$

80C 2
90S 2
90L 4
90LB 6
100A 6

200	7	62	5.2	UMI 90	90L 4
200	7	61	3.4	UMI 75	90L 4
200	7	60	1.9	UMI 63	90L 4
189	15	63	4.4	UMI 90	80C 2
189	15	62	2.7	UMI 75	90S 2
189	15	62	2.7	UMI 75	80C 2
189	15	62	1.6	UMI 63	90S 2
189	15	62	1.6	UMI 63	80C 2
140	10	87	4.0	UMI 90	90L 4
140	10	86	2.6	UMI 75	90L 4
140	10	85	1.5	UMI 63	90L 4
93	15	126	2.9	UMI 90	90L 4
93	15	124	1.9	UMI 75	90L 4
93	15	123	1.1	UMI 63	90L 4
70	20	164	2.3	UMI 90	90L 4
70	20	160	1.4	UMI 75	90L 4
70	20	158	0.9	UMI 63	90L 4
63	15	183	2.4	UMI 90	100A 6
63	15	181	1.4	UMI 75	100A 6
62	15	186	2.3	UMI 90	90LB 6
62	15	184	1.4	UMI 75	90LB 6
58	49	176	1.6	UMI 90	80C 2
58	49	176	1.6	UMI 90	90S 2
58	49	176	0.9	UMI 75*	80C 2
58	49	176	0.9	UMI 75*	90S 2
51	56	201	1.4	UMI 90	80C 2
51	56	201	1.4	UMI 90	90S 2
50	28	212	2.0	UMI 90	90L 4
50	28	212	1.2	UMI 75	90L 4
46	20	242	1.8	UMI 90	90LB 6
46	20	238	1.0	UMI 75	90LB 6
40	70	237	1.0	UMI 90	80C 2
40	70	237	1.0	UMI 90	90S 2
35	40	291	1.4	UMI 90	90L 4
35	40	287	0.8	UMI 75*	90L 4
29	49	336	1.1	UMI 90	90L 4
25	56	390	0.9	UMI 90	90L 4
24	40	408	1.1	UMI 90	100A 6
23	40	415	1.1	UMI 90	90LB 6
19	49	478	0.9	UMI 90	100A 6
19	49	486	0.9	UMI 90	90LB 6

Примечание.

Указанная мощность основана на механической мощности редукторов.

Для редукторов, отмеченных знаком (*), также необходимо учитывать предельную тепловую мощность, как указано в Разделе 1.7.



STANDARD *line*



STANDARD *line*

n_2 min ⁻¹	ir	T2 Nm	FS'		
1.8 kW					
				$n_1 = 2770 \text{ min}^{-1}$ $n_1 = 1400 \text{ min}^{-1}$ $n_1 = 940 \text{ min}^{-1}$	80D 2 90LB 4 100B 6

396	7	37	6,2	UMI 90	80D 2
396	7	37	3,8	UMI 75	80D 2
396	7	37	2,2	UMI 63	80D 2
396	7	37	1,4	UMI 50*	80D 2
277	10	53	4,8	UMI 90	80D 2
277	10	52	3,0	UMI 75	80D 2
277	10	52	1,8	UMI 63	80D 2
277	10	52	1,1	UMI 50*	80D 2
200	7	74	4,3	UMI 90	90LB 4
200	7	73	2,8	UMI 75	90LB 4
200	7	72	1,6	UMI 63	90LB 4
185	15	77	3,6	UMI 90	80D 2
185	15	76	2,2	UMI 75	80D 2
185	15	76	1,3	UMI 63*	80D 2
140	10	104	3,3	UMI 90	90LB 4
140	10	103	2,1	UMI 75	90LB 4
140	10	102	1,2	UMI 63	90LB 4
93	15	151	2,5	UMI 90	90LB 4
93	15	148	1,5	UMI 75	90LB 4
93	15	147	0,9	UMI 63*	90LB 4
70	20	196	1,9	UMI 90	90LB 4
70	20	194	1,1	UMI 75	90LB 4
57	49	216	1,3	UMI 90	80D 2
57	49	216	0,8	UMI 75*	80D 2
50	28	254	1,6	UMI 90	90LB 4
50	28	254	1,0	UMI 75*	90LB 4
49	56	247	1,1	UMI 90*	80D 2
40	70	291	0,8	UMI 90*	80D 2
35	40	349	1,2	UMI 90	90LB 4
29	49	403	0,9	UMI 90*	90LB 4

2.2 kW					
				$n_1 = 2840 \text{ min}^{-1}$ $n_1 = 1410 \text{ min}^{-1}$ $n_1 = 950 \text{ min}^{-1}$	90L 2 100A 4 112A 6

406	7	45	5,2	UMI 90	90L 2
406	7	45	3,2	UMI 75	90L 2
406	7	45	1,9	UMI 63*	90L 2
284	10	63	4,1	UMI 90	90L 2
284	10	63	2,5	UMI 75	90L 2
284	10	62	1,5	UMI 63*	90L 2
189	15	92	3,0	UMI 90	90L 2
189	15	91	1,8	UMI 75	90L 2
189	15	91	1,1	UMI 63*	90L 2
141	10	127	2,7	UMI 90	100A 4
141	10	125	1,8	UMI 75	100A 4
101	28	159	1,2	UMI 75*	90L 2
396	7	37	6,2	UMI 90	80D 2
396	7	37	3,8	UMI 75	80D 2
277	10	53	4,8	UMI 90	80D 2
277	10	53	3,0	UMI 75	80D 2

n_2 min ⁻¹	ir	T2 Nm	FS'		
2.2 kW					
				$n_1 = 2840 \text{ min}^{-1}$ $n_1 = 1410 \text{ min}^{-1}$ $n_1 = 950 \text{ min}^{-1}$	90L 2 100A 4 112A 6

200	7	74	4,3	UMI 90	90LB 4
200	7	73	2,8	UMI 75	90LB 4
141	10	127	2,7	UMI 90	100A 4
101	28	157	2,0	UMI 90	90L 2
101	28	159	1,2	UMI 75*	90L 2
94	15	183	2,0	UMI 90	100A 4
94	15	181	1,3	UMI 75	100A 4
71	20	238	1,6	UMI 90	100A 4
71	20	235	0,9	UMI 75*	100A 4
63	15	268	1,6	UMI 90	100BL 6
63	15	265	1,0	UMI 75*	100BL 6
50	28	309	1,3	UMI 90	100A 4
50	28	309	0,8	UMI 75*	100A 4
35	40	423	1,0	UMI 90	100A 4

3 kW					
				$n_1 = 2840 \text{ min}^{-1}$ $n_1 = 2860 \text{ min}^{-1}$ $n_1 = 1420 \text{ min}^{-1}$ $n_1 = 940 \text{ min}^{-1}$ $n_1 = 950 \text{ min}^{-1}$	90L 2 100A 2 100B 4 112B 6 132S 6

409	7	60	3,8	UMI 90	100A 2
406	7	61	2,3	UMI 75*	90LB 2
406	7	61	1,4	UMI 63*	90LB 2
284	10	86	3,0	UMI 90	90LB 2
284	10	86	1,8	UMI 75*	90LB 2
284	10	85	1,1	UMI 63*	90LB 2
203	7	121	2,6	UMI 90	100B 4
203	7	120	1,7	UMI 75*	100B 4
189	15	126	2,2	UMI 90	90LB 2
189	15	124	1,3	UMI 75*	90LB 2
189	15	124	0,8	UMI 63*	90LB 2
142	10	171	2,0	UMI 90	100B 4
142	10	169	1,3	UMI 75*	100B 4
134	7	181	2,1	UMI 90	112B 6
134	7	179	1,3	UMI 75*	112B 6
102	28	213	1,5	UMI 90*	100A 2
102	28	216	0,9	UMI 75*	100A 2
101	28	215	1,5	UMI 90*	90LB 2
101	28	217	0,9	UMI 75*	90LB 2
95	15	248	1,5	UMI 90	100B 4
95	15	245	0,9	UMI 75*	100B 4
94	10	256	1,6	UMI 90	112B 6
94	10	253	1,0	UMI 75*	112B 6
72	40	293	1,1	UMI 90*	100A 2
71	40	295	1,1	UMI 90*	90LB 2
71	20	323	1,2	UMI 90	100B 4
63	15	366	1,2	UMI 90*	112B 6
58	49	349	0,8	UMI 90*	100A 2
58	49	351	0,8	UMI 90*	90LB 2

n_2 min ⁻¹	ir	T2 Nm	FS'		
4 kW					
				$n_1 = 2860 \text{ min}^{-1}$ $n_1 = 2860 \text{ min}^{-1}$ $n_1 = 1410 \text{ min}^{-1}$ $n_1 = 1425 \text{ min}^{-1}$ $n_1 = 950 \text{ min}^{-1}$	100B 2 112A 2 100BL 4 112A 4 132M 6

409	7	80	2,9	UMI 90	100B 2
409	7	80	2,9	UMI 90	112A 2
409	7	80	1,8	UMI 75*	100B 2
409	7	80	1,8	UMI 75*	112A 2
286	10	114	2,2	UMI 90*	100B 2
286	10	114	2,2	UMI 90*	112A 2
286	10	114	1,4	UMI 75*	100B 2
286	10	114	1,4	UMI 75*	112A 2
204	7	161	2,0	UMI 90	112A 4
204	7	160	1,3	UMI 75*	112A 4
201	7	163	2,0	UMI 90	100BL 4
201	7	161	1,3	UMI 75*	100BL 4
191	15	166	1,7	UMI 90*	100B 2
191	15	166	1,7	UMI 90*	112A 2
191	15	164	1,0	UMI 75*	100B 2
191	15	164	1,0	UMI 75*	112A 2
143	20	219	1,3	UMI 90*	100B 2
143	20	219	1,3	UMI 90*	112A 2
143	10	228	1,5	UMI 90*	112A 4
143	10	225	1,0	UMI 75*	112A 4
141	10	230	1,5	UMI 90*	100BL 4
141	10	228	1,0	UMI 75*	100BL 4
102	28	284	1,1	UMI 90*	100B 2
102	28	284	1,1	UMI 90*	112A 2
95	15	330	1,1	UMI 90*	112A 4
94	15	333	1,1	UMI 90*	100BL 4
72	40	390	0,8	UMI 90*	100B 2
72	40	390	0,8	UMI 90*	112A 2
71	20	429	0,9	UMI 90*	112A 4
71	20	433	0,9	UMI 90*	100BL 4

5.5 kW					
				$n_1 = 2880 \text{ min}^{-1}$ $n_1 = 1440 \text{ min}^{-1}$ $n_1 = 1400 \text{ min}^{-1}$	112B 2 132S 4 112BL 4

411	7	110	2,1	UMI 90*	112B 2
411	7	110	1,3	UMI 75*	112B 2
288	10	155	1,6	UMI 90*	112B 2
288	10	155	1,0	UMI 75*	112B 2
200	7	226	1,4	UMI 90*	112BL 4
200	7	223	0,9	UMI 75*	112BL 4
192	15	227	1,2	UMI 90*	112B 2
144	20	299	1,0	UMI 90*	112B 2
140	10	319	1,1	UMI 90*	112BL 4
103	28	388	0,8	UMI 90*	112B 2
93	15	461	0,8	UMI 90*	112BL 4



**7.5 kW**

$n_1 = 2890 \text{ min}^{-1}$	132SL 2
$n_1 = 2860 \text{ min}^{-1}$	112BL 2
$n_1 = 1440 \text{ min}^{-1}$	132M 4

409	7	151	1,5	UMI 90*	112BL 2
409	7	151	0,9	UMI 75*	112BL 2
286	10	213	1,2	UMI 90*	112BL 2
191	15	312	0,9	UMI 90*	112BL 2

Примечание.

Указанная мощность основана на механической мощности редукторов.

Для редукторов, отмеченных знаком (*), также необходимо учитывать предельную тепловую мощность, как указано в Разделе 1.7.



3.8 *Размеры*

U (40 - 90)

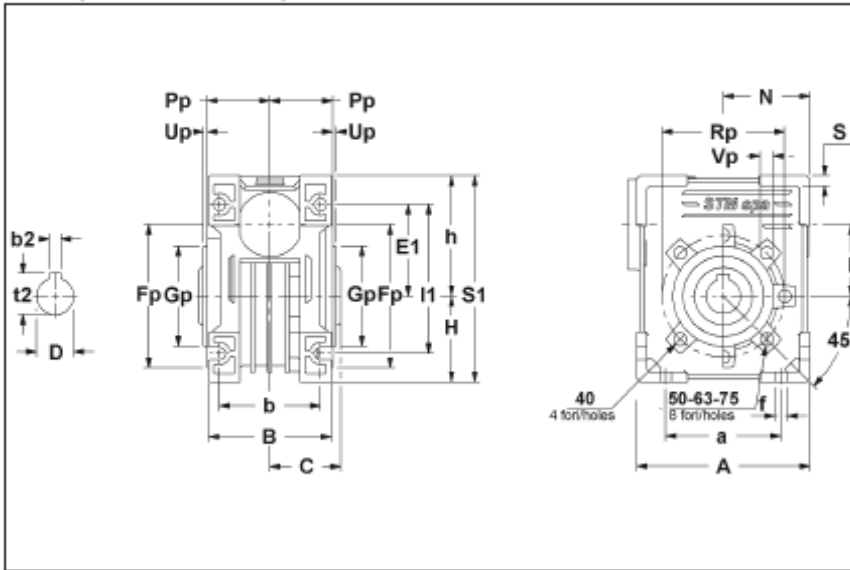

UI (40 - 90)

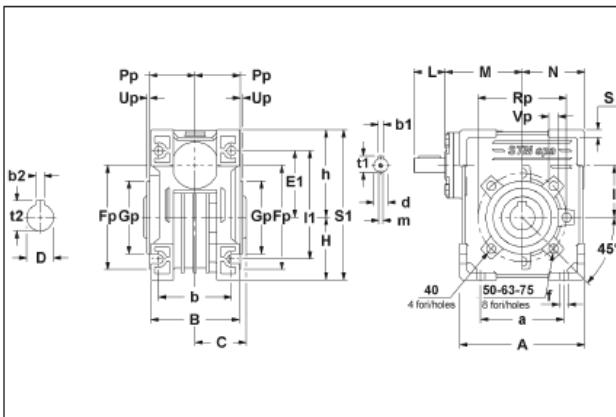

UMI (40 - 90)

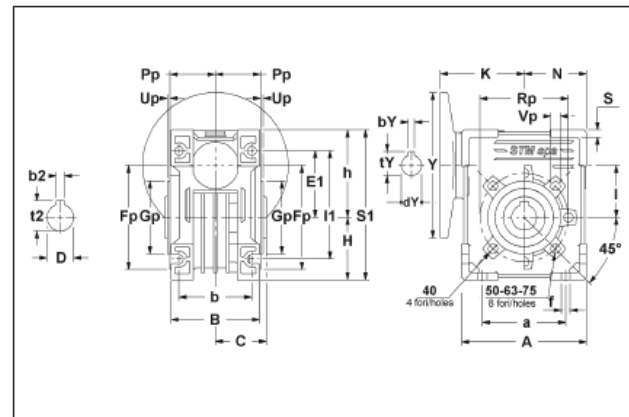

UI FA - FB (40 - 90)

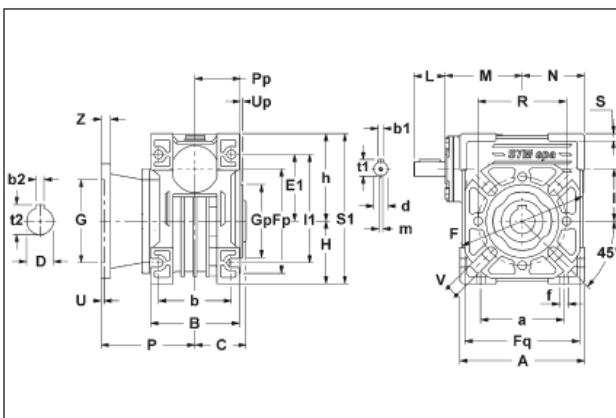

UMI FA - FB (40 - 90)

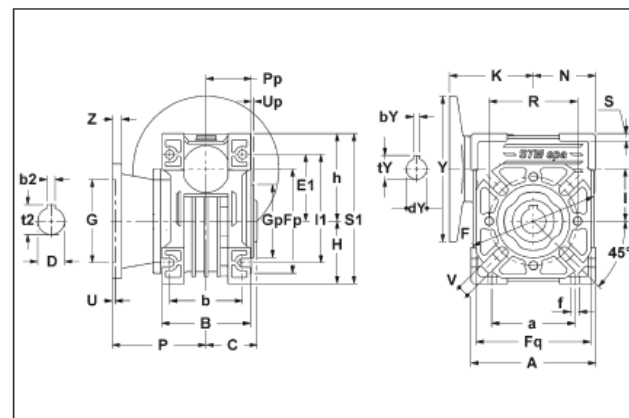



U - UI UMI	A	a	B	b	C	D _{H7}	d _{j6}	E1	f	h	H	I	II	L	M	m	N	S	S1
40	100	70	71	60	39	18	11	55	6.5	71.5	50	40	90	22	64	M5	50	6	121.5
50	120	80	85	70	46	25	14	64	8.5	84	60	50	104	30	74	M6	60	7	144
63	144	100	103	85	56	25	18	80	8.5	102	72	63	130	45	96	M6	72	8	174
75	172	120	112	90	60	28	24	93	11.5	119	86	75	153	50	105	M8	86	10	205
90	206	140	130	100	70	35	24	102	13	135	103	90	172	50	125	M8	103	11	238

U - UI - UMI	Fp	Gp (g6)	Pp	Rp	Up	Vp
40	87	60	36.5	75	2.5	M6
50	100	70	43.5	85	2.5	M8
63	110	80	53	95	3	M8
75	140	95	57	115	3	M8
90	160	110	67	130	3	M10

U - UI - UMI	F	Fq	G (g6)	P	R	U	V	Z	
40	FA	110	95	67	75	4	9	7	
	FB		95	97					
50	FA	125	110	90	85	5	11	9	
	FB		110	120					
63	FA	180	142	82	150	6	11	10	
	FB		142	112					
75	FA	200	170	130	111	165	6	14	13
	FB	160	160	110	90	130	5	11	12
90	FA	210	200	152	111	175	6	14	13
	FB	250	210	180	122	215	6	14	16

	UMI											
	40		50		63		75		90			
	Y	K	Y	K	Y	K	Y	K	Y	K		
B5	120	70	140	80.5	160	95	200	118	200	128		
	140		160		200		250		120		250	130
	160		200		—		—		—		—	—
B14	90 •	70	120	80.5	105 •	95	120	118	120	128		
	105		105 •		120		140		120		140	128
	—		—		90 •		140		160		120	160

(•) См. примечание в конце таблицы 2.13.



3.9 Аксессуары: Реактивный кронштейн

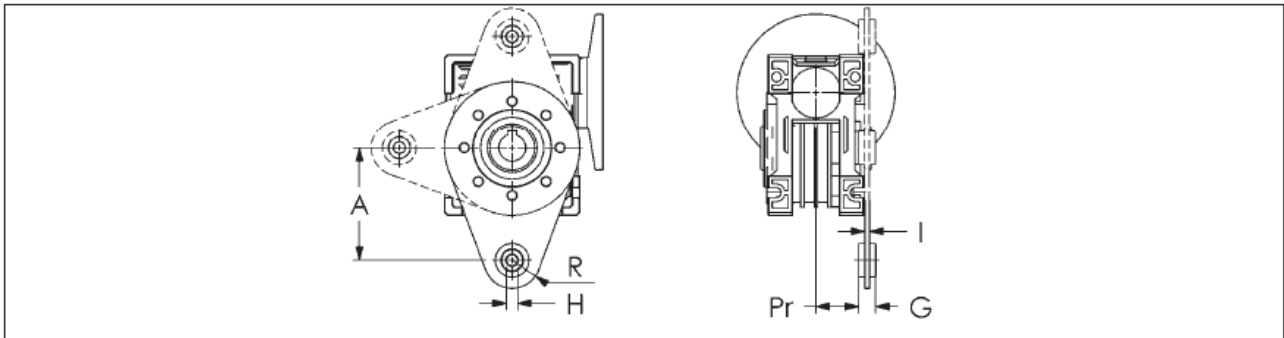

UI - UMI	40	50	63	75	90
A	100	100	150	200	200
G	15	15	20	25	25
H	10	10	10	20	20
I	4	4	6	6	6
Pr	31	38	48.5	47.5	57.5

3.10 Аксессуары: Выходные валы

Все червячные редукторы поставляются с полым выходным валом. Выходные валы, представленные на чертеже с размерами, поставляются по запросу. Размеры шпонок в соответствии со стандартом UNI 6604-69.

Односторонний вал

Двусторонний вал

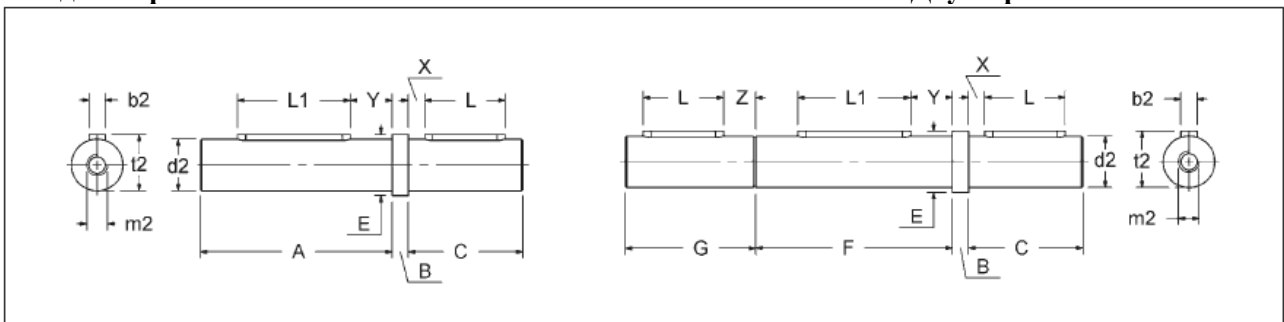

	UI - UMI				
	40	50	63	75	90
A	76	89	109	117	137
B	10	10	10	10	10
C	40	45	60	60	80
d2 g6	18	25	25	28	35
m2	M8	M8	M8	M8	M10
E	22	28	34	34	38
F	78	92	112	120	140
G	50	55	70	70	90
L	25	30	40	40	50
L1	40	50	60	60	70
X	8	7.5	10	10	15
Y	21	24	30	30	37
Z	18	18	20	20	25



3.11 Шпонки

Входной вал

UI		
d	b ₁	t ₁
9	3	10.2
11	4	12.5
14	5	16.0
16	5	18.0
18	6	20.5
19	6	21.5
24	8	27.0
25	8	28.0
28	8	31.0
30	8	33.0
32	10	35.0
35	10	38.0
38	10	41.0
42	12	45.0
45	14	48.5
48	14	51.5
50	14	53.5
55	16	59.0
65	18	69.0

UMI - PAM B5				
PAM B5	Y	dY	bY	tY
56	120	9	3	10.4
63	140	11	4	12.8
71	160	14	5	16.3
80	200	19	6	21.8
90	200	24	8	27.3
100	250	28	8	31.3
112	250	28	8	31.3
132	300	38	10	41.3
160	350	42	12	45.3
180	350	48	14	51.8
200	400	55	16	59.3

UMI - PAM B14				
PAM B14	Y	dY	bY	tY
56	80	9	3	10.4
63	90	11	4	12.8
71	105	14	5	16.3
80	120	19	6	21.8
90	140	24	8	27.3
100	160	28	8	31.3
112	160	28	8	31.3
132	200	38	10	41.3

Выходной вал

Полый вал U-UI-UMI		
D	b ₂	t ₂
14	5	16.3
18	6	20.8
19	6	21.8
24	8	27.3
25	8	28.3
28	8	31.3
30	8	33.3
32	10	35.3
35	10	38.3
42	12	45.3
45	14	48.8
48	14	51.8
50	14	53.8
55	16	59.3
65	18	69.4

Цилиндрический вал U-UI-UMI		
d ₂	b ₂	t ₂
9	3	10.2
11	4	12.5
14	5	16.0
16	5	18.0
18	6	20.5
19	6	21.5
24	8	27.0
25	8	28.0
28	8	31.0
30	8	33.0
32	10	35.0
35	10	38.0
38	10	41.0
42	12	45.0
45	14	48.5
48	14	51.5
50	14	53.5
55	16	59.0
65	18	69.0